

A family of quantum codes with performances close to the hashing bound under iterative decoding

Denise Maurice*, Jean-Pierre Tillich*, Iryna Andriyanova †

* INRIA, Equipe Secret, Domaine de Voluceau BP 105, F-78153 Le Chesnay cedex, France.

† ETIS group, ENSEA/University of Cergy-Pontoise/CNRS-UMR8051, France

Abstract—We propose here a new construction of quantum codes combining an improved version of a family of spatially coupled quantum LDPC codes, suggested in [1], with a family of error reducing turbo-codes of [2]. This new construction displays outstanding performances under iterative decoding for noise levels very close to the hashing bound, without needing qubits, protected from noise as in [1].

I. INTRODUCTION

Quantum capacity. One of the most challenging issues in quantum information theory is determining the maximum rate at which information can be transmitted through a quantum channel. In particular we will be interested in the quantum channel capacity which captures such a notion when the information to be protected is quantum. Even for very simple and natural noise models such as the depolarizing channel, this quantity is not known accurately, there only exist upper and lower bounds, being rather far apart (see for instance [3]). The simplest lower bound is known as the hashing bound or the LSD theorem [4], [5], [6]. It has a very simple form for Pauli channels and can be attained by random stabilizer codes. Roughly speaking, the hashing bound corresponds to the maximum rate for which the information about the error, obtained by the syndrome measurement, is able to pinpoint the Pauli error. In some sense, it really corresponds to the classical notion of capacity. In the case of the depolarizing channel, this lower bound has only been improved by a tiny amount [7], [8], [9].

Quantum codes suitable for iterative decoding. Another very challenging task is to devise coding schemes which would attain these lower bounds with a decoding algorithm of low complexity. Recently in [10], a scheme, attaining the hashing bound of Pauli channels, was proposed. It is basically a quantum version of polar codes [11]. It presents the same advantages as classical polar codes, in particular it inherits the low complexity decoding algorithm of its classical counterpart. However, this coding scheme needs assistance of some entangled qubits, which are shared between the encoder and the decoder and which are noiseless on the decoder side. Moreover, the performance of classical polar codes is significantly superseded by the performance of well designed sparse-graph codes, for instance LDPC codes or turbo-codes, which have also a low complexity decoding algorithm (i.e. the iterative decoding algorithm). This is basically due to the fact that the probability of error after decoding decreases much

slower in the polar code case than for LDPC codes or turbo-codes.

This motivates us to search for a good quantum analogue of LDPC codes or turbo-codes. However, it turns out that the design of high performance quantum LDPC codes is much more complicated than in the classical setting. In particular, most constructions suggested in the literature [12], [13], [14], [15], [16], [17], [18], [19], [20] suffer from having either a bounded minimum distance or a vanishing code rate. There are only few exceptions, namely [21], [22], [23], [24]. Moreover in all these constructions, unlike in the classical setting, there are issues with the decoder: 4-cycles in their Tanner graph if decoding is performed over \mathbb{F}_4 and code degeneracy which impairs the decoder [25].

On the other hand, the generalization of turbo-codes to the quantum setting has first been achieved in [26]. However this construction has rather poor iterative decoding performance. In [27], it was shown that it was possible to come up with quantum turbo-codes with good performance under iterative decoding. However, the families of codes constructed in this article have bounded minimum distance and the performance of these codes degrades for large blocklengths. It was even proved there that it is not possible to obtain quantum serial turbo-codes with unbounded minimum distance and with an iterative decoding algorithm that converges. This is due to the fact that it can be proved that quantum convolutional encoders which are at the same time non-catastrophic and recursive do not exist [27].

In summary, all these quantum constructions are very far away from being able to perform close to the hashing bound. For instance, if we consider the constructions obtained for rate $\frac{1}{4}$, for which we have the most of experimental data, none of these codes are able to operate successfully at depolarizing noise p above $p = 0.08$ (actually the sustainable noise for the best of these constructions ranges between $p = 0.04$ and $p = 0.08$) whereas the hashing bound for rate $\frac{1}{4}$ corresponds to the depolarizing noise of about $p \approx 0.127$.

Spatially coupled quantum LDPC codes. The difficulty of obtaining good quantum LDPC codes is arguably the fact that in order to avoid the deterioration of decoding performance due to the code degeneracy, LDPC codes of rather large parity-check weights should be used. In the classical case, such LDPC codes can operate successfully near capacity, if the degree distribution is carefully optimized. This is much more difficult to achieve in the quantum setting due to the orthogonality

constraints that the parity-check matrix has to satisfy. There is however a way in the classical case to operate successfully near capacity with LDPC codes with large parity-checks and without the degree distribution optimization – by using spatially coupled quantum codes [28].

Spatially coupled LDPC have been introduced in [29] (they were named terminated convolutional LDPC codes there). They might be viewed in the following way: take several several instances of a certain LDPC code family (denoted by *layers*), arrange them in a row and then mix the edges of the codes randomly among neighboring layers (ie swapping the end point of two edges of neighboring layers). Moreover fix the bits of the first and the last layers to zero. It has soon been found out that iterative decoding behaves much better for this code than for the original LDPC code and that it was easy to get very close to the capacity by starting from almost any LDPC code without any optimization of the degree distribution. A breakthrough occurred when it was proved that a single class of such codes is able to attain the capacity of all binary input memoryless output-symmetric channels [28].

Quantum spatially coupled LDPC codes. All these nice features of classical spatially coupled LDPC codes suggest to study whether they have a quantum analogue. A first step in this direction was achieved in [30] where a certain family of quantum spatially coupled LDPC codes was suggested (but without using well protected qubits which would be the quantum analogue of fixing bits to zero). However, the performances of these codes are still very far away from the hashing bound. Another route was followed in [1], where a spatially coupled version of a construction of quantum LDPC codes, suggested by [15] and based on a couple of orthogonal (classical) LDPC codes obtained from low density generator matrix (LDGM) codes. They gave a stabilizer code of rate $\frac{1}{4}$ and a few first layers and a few last layers of the spatially coupled construction are supposed to be error-free. A tremendous performance improvement over other families of codes of rate $\frac{1}{4}$ is then observed. In this case, the probability of error after decoding drops down sharply after $p = 0.102$.

Our contribution. We have revisited the construction of [1] in several ways. First of all, we have removed the assumption of having qubits noise-free by protecting the first and the last layers of the construction by encoding the qubits of these layers with the quantum turbo-code of [2], which is a strong error-reducing code. Our code is as in [1] a CSS code [31], [32]. The two associated binary codes are decoded separately in [1]. We have changed the decoding algorithm by coupling both decoders here. Finally we have also devised with greater care the coupling used in [1]. All these transformations result in a code construction whose rate goes to $\frac{1}{4}$ and which performs extremely well under iterative decoding for noise values close to the hashing bound $p \approx 0.127$, and this without needing qubits which are error-free as in [1].

II. CSS CODES

The codes constructed in this paper fall into the category of Calderbank-Shor-Steane (CSS) codes [31], [32] which belong

to a more general class of quantum codes called stabilizer codes [33], [34]. The first class is described with the help of a pair of mutually orthogonal binary codes, whereas the second class is given by an additive self-orthogonal code over $GF(4)$ with respect to the trace Hermitian inner product. Quantum codes on n qubits are linear subspaces of a Hilbert space of dimension 2^n and do not necessarily have a compact representation in general. The nice feature of stabilizer codes is that they allow to define such a space with the help of a very short representation, which is given here by a set of generators of the aforementioned additive code. Each generator is viewed as an element of the Pauli group on n qubits and the quantum code is then nothing but the space stabilized by these Pauli group elements. Moreover, the set of errors that such a quantum code can correct can also be deduced directly from this discrete representation. For the subclass of CSS codes, this representation in terms of additive self-orthogonal codes is equivalent to a representation in terms of a pair $(\mathcal{C}_X, \mathcal{C}_Z)$ of binary linear codes satisfying the condition $\mathcal{C}_Z^\perp \subset \mathcal{C}_X$. The *quantum minimum distance* of such a CSS code is given by

$$\begin{aligned} d_Q &\triangleq \min\{d_X, d_Z\}, \text{ where} & (1) \\ d_X &\triangleq \min\{|x|, x \in \mathcal{C}_X \setminus \mathcal{C}_Z^\perp\}, \\ d_Z &\triangleq \min\{|x|, x \in \mathcal{C}_Z \setminus \mathcal{C}_X^\perp\}. \end{aligned}$$

Such a code allows to protect a subspace of k_Q qubits against errors, where

$$k_Q \triangleq \dim(\mathcal{C}_X / \mathcal{C}_Z^\perp). \quad (2)$$

k_Q is called the *quantum dimension* of the CSS code.

If \mathbf{H}_X and \mathbf{H}_Z are parity-check matrices of the binary codes \mathcal{C}_X and \mathcal{C}_Z respectively, the pair $(\mathbf{H}_X, \mathbf{H}_Z)$ is referred to either as the *stabilizer matrix* or as the parity-check matrix of the quantum code, by analogy with the classical case. The condition $\mathcal{C}_Z^\perp \subset \mathcal{C}_X$ translates into $\mathbf{H}_X \mathbf{H}_Z^T = 0$.

The channel error model we will be interested in is called a Pauli channel. The parameters of such an error model consist in a triple of non-negative reals p_X, p_Y, p_Z satisfying $p_X + p_Y + p_Z \leq 1$. In the case of n qubits, an error consists in a couple of two binary errors $\mathbf{e}_X = (e_i^X)_{1 \leq i \leq n}$ and $\mathbf{e}_Z = (e_i^Z)_{1 \leq i \leq n}$ of length n which obey to the following error model

$$\begin{aligned} \mathbf{P}(e_i^X = 1, e_i^Z = 0) &= p_X \\ \mathbf{P}(e_i^X = 0, e_i^Z = 1) &= p_Z \\ \mathbf{P}(e_i^X = 1, e_i^Z = 1) &= p_Y \end{aligned}$$

In the case of a CSS code, the associated decoding problem can be formalized as follows. Let n be the length of the CSS code. We want to decode simultaneously the aforementioned couple $(\mathbf{e}^X, \mathbf{e}^Z)$ from the knowledge of the syndrome of both errors which are given by $\mathbf{H}_X \mathbf{e}_X^T$ and $\mathbf{H}_Z \mathbf{e}_Z^T$.

III. OUR CONSTRUCTION

A. Outline of the construction

Our construction has two ingredients:

Fig. 1. Rough sketch of the construction. U is the outer spatially coupled quantum LDPC encoder where the qubits are arranged in layers. The block structure of U corresponds to these layers and the turbo-code encoder U_{in}^T of [2] can be viewed as an inner encoder protecting the layers at the extremity. The decoding is done in two steps. First, the inverse inner encoder is applied, the syndrome is measured and the turbo-code is decoded, and a suitable correction $U_{d,ext}$ procedure is applied before decoding the outer spatially coupled LDPC code.

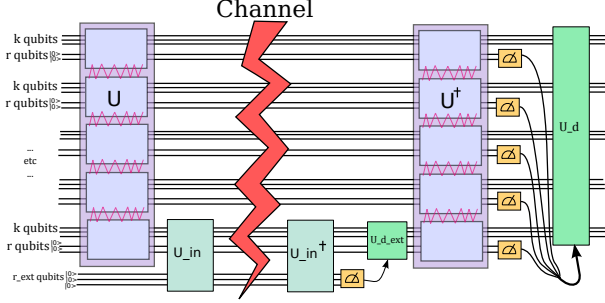

- a spatially coupled version of a quantum LDPC construction due to [35], [15];
- an error-reducing code taken from [2] which reduces strongly the noise in the outer layers of our construction.

Figure 1 gives a rough sketch of the overall construction.

B. Overview of the construction of [15]

Before presenting our construction of a spatially coupled LDPC code, let us recall the approach of [35], [15] which we followed. Their idea begins with the observation that the dual of a low density generator matrix code is a low density parity-check code. This can be exploited to yield a CSS code at the expense of a constant minimum distance. However, if the weights of the rows of the low density generator matrix are chosen to be large enough, this is not necessarily a problem.

A couple of matrices $(\tilde{\mathbf{H}}_X, \tilde{\mathbf{H}}_Z)$ satisfying the orthogonality constraint $\tilde{\mathbf{H}}_X \tilde{\mathbf{H}}_Z^T = 0$ are obtained as follows. Start with an $n/2 \times n/2$ sparse binary matrix \mathbf{P} . Let $\tilde{\mathbf{H}}_X = (\mathbf{P} \mid \mathbf{I})$, $\tilde{\mathbf{H}}_Z = (\mathbf{I} \mid \mathbf{P}^T)$. Obviously, $\tilde{\mathbf{H}}_X \tilde{\mathbf{H}}_Z^T = 0$. However this gives a quantum code of length n , and of rate 0. We can nevertheless obtain a quantum code of non zero rate by either choosing a subset of rows in $\tilde{\mathbf{H}}_X$ and $\tilde{\mathbf{H}}_Z$ to form \mathbf{H}_X and \mathbf{H}_Z respectively or by multiplying these matrices from the left by arbitrary non-square matrices \mathbf{M}_X and \mathbf{M}_Z (say of size $l \times n/2$): $\mathbf{H}_X = \mathbf{M}_X \tilde{\mathbf{H}}_X$ and $\mathbf{H}_Z = \mathbf{M}_Z \tilde{\mathbf{H}}_Z$.

The resulting CSS code associated to the couple $(\mathbf{H}_X, \mathbf{H}_Z)$ is still of length n but his rate is now $1 - 2l/n$. Since we are interested in codes of rate $\frac{1}{4}$, we choose $l = \frac{3}{8}$. For remaining parameters, let us proceed as in [15]: \mathbf{P} will be chosen to be of constant row and column weight d . \mathbf{M}_X and \mathbf{M}_Z are chosen as in [15]: they have constant column weight equal to x , and we fix their row weight to 1 on s_1 rows and to y on the remaining s_2 rows. These s_1 rows of weight 1 help the decoding to start. Therefore we have $s_1 = n \frac{3x-4y}{4(x-1)}$ and $s_2 = n \frac{4y-3}{4(x-1)}$.

We represent this construction with a Tanner graph which will be used for decoding (see Figure 2 and [15] for further

Fig. 2. Tanner graph used for decoding. The graph of \mathbf{H}_X is represented in the upper part, and the graph of \mathbf{H}_Z in the lower part. The green boxes (grey outline) represent the matrix \mathbf{P} in the X-part, and \mathbf{P}^T in the Z-part. The purple boxes (dashed outline) represent \mathbf{M}_X and \mathbf{M}_Z respectively.

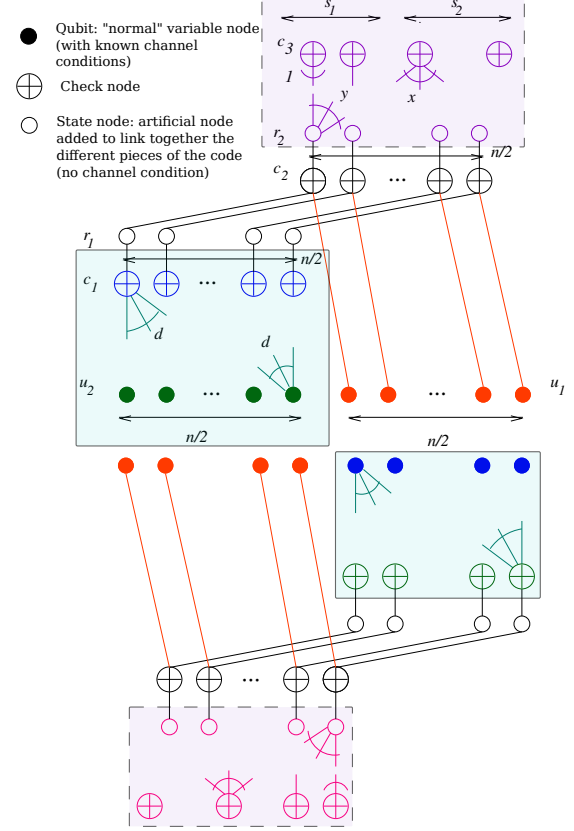

details). There are n variable nodes. Half of them are of degree 1 (they correspond to u_1 in the X-part, u_2 in the Z-part) in the Tanner graph, while the other half (which corresponds to u_2 in the X-part and u_1 in the Z-part) is of some constant degree d . There is a first set of check nodes, corresponding to c_1 , all of degree $d+1$ which form a bipartite subgraph of degree d with the variable nodes of degree d . This first level of the graph represents the matrix \mathbf{P} : the check nodes correspond to the rows of \mathbf{P} whereas the variable nodes correspond to the columns of \mathbf{P} . There is an edge between a check node and a variable node if and only if the corresponding entry in \mathbf{P} contains a 1.

There is a matching of these check nodes with $n/2$ state nodes (corresponding to r_1 in the figure) and there are two matchings between the $n/2$ check nodes of the second level (corresponding to c_2) and the variable nodes of u_1 and r_1 respectively. Then there is a last matching between the $n/2$ check nodes of c_2 and the $n/2$ state nodes of r_2 . Finally the subgraph of the Tanner graph formed by the state nodes of r_2 and the last level of check nodes corresponding to c_3 has three type of nodes:

- s_1 check nodes of degree 1 (this implies that the associated state node of r_2 should be equal to 0),

- s_2 check nodes of some constant degree x ,
- all the state nodes of r_2 are of some constant degree y in the subgraph. This part of the graph represents the matrix \mathbf{M}_X in the same way as \mathbf{P} was represented before.

As explained before, the purpose of the check nodes of degree 1 of the last level is to ensure that iterative decoding does not get stuck at the initial stage (it corresponds to some kind of doping of the last level of state nodes corresponding to r_2).

C. The associated spatially coupled construction

The point of choosing the construction of [15] is that it has already good performances and leads in a natural way to a spatially coupled version, still preserving the orthogonality constraints for \mathbf{H}_X and \mathbf{H}_Z . The spatially coupled version is obtained by taking several codes, constructed in the previous subsection, and swapping the edges of the Tanner graphs of these codes. More precisely, it is done as follows: we choose three parameters L, δ_P and δ_M . Let $\delta \triangleq \max(\delta_M, \delta_P)$. Take $L + 2\delta$ copies of codes of length n coming, index them with $0, 1, \dots, L + 2\delta - 1$ and consider the associated Tanner graphs (let the t -th Tanner graph correspond to *layer* t). For each $i \in \{-\delta_P, \dots, \delta_P\}$, and $t \in \{0, 1, \dots, L + 2\delta_P - 1\}$, we swap a fraction $\frac{1}{2\delta_P + 1}$ of the edges which link a variable node with a check node at layer t (and which correspond to \mathbf{P}) with an edge which links a variable node to a check node at level $t + i \bmod (L + 2\delta)$ such that the variable node at level t is now adjacent to the check node at level $t + i \bmod (L + 2\delta)$ and vice versa. The edges which link the state nodes with check nodes which correspond to \mathbf{M}_X are treated similarly, but with δ_M replacing δ_P in the explanations above. As seen in Figure 3, in the X -part, we couple up to a distance δ_P the edges from P , and up to a distance δ_M the edges from M_X .

Fig. 3. Coupling the edges of the X -part: each of the four little graphs is a contracted version of fig 2. The coupling is made by mixing the edges of $\mathbf{M}_X, \mathbf{M}_Z, \mathbf{P}$ and \mathbf{P}^T .

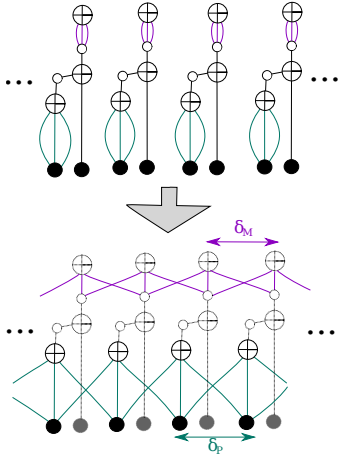

For the Z -part, we just transpose the extended (and spatially coupled) \mathbf{P} . Then we naturally have the orthogonality condition, and each edge is sent to a distance at most δ_P . M_Z is coupled independently, up to a distance δ_M . Even if this is

not obvious, this coupling is necessary: suppose that, at some step of the decoding, the X -part, the u_2 section (the half of the information nodes that are of degree d) has been correctly decoded. Erase these variable nodes and the adjacent edges from the graph. Then the resulting Tanner graph is exactly the one which we use if we want to correct the remaining errors. It corresponds just to the matrix M_X , with the u_1 nodes replacing the r_2 nodes. If this section is not spatially coupled, it is equivalent to $L + 2\delta$ distinct codes. Therefore the decoding performances are catastrophic: as L increases, the probability that at least one of those independent decoding fails tends to 1.

Finally the qubits which are in the layers $\{0, \dots, 2\delta - 1\}$ will be protected by a second encoding which uses the turbo-code of [2]. This turbo-code is of rate $\frac{1}{8}$ and therefore the parameters of the whole construction can be described as follows.

- length = $Ln + 2\delta n \times 8 = (L + 16\delta)n$,
- number of encoded qubits = $\frac{(L+2\delta)n}{4}$
- rate = $\frac{(L+2\delta)n}{4(L+16\delta)n} = \frac{L+2\delta}{4(L+16\delta)}$ which tends asymptotically to $\frac{1}{4}$ as L tends to infinity.

IV. RESULTS

The decoding starts by decoding the inner turbo-code first. It reduces significantly the error noise on the first layers (less than a fraction of $\frac{1}{1000}$ of qubits were incorrectly decoded by using this decoder). This information is passed directly to the decoder of the spatially coupled LDPC code, the belief propagation decoding is performed over the Tanner graph, associated to the construction. Note that one decoder the X and Z errors simultaneously (and therefore the correlations of these errors are taken into account). For the belief propagation decoder, the window decoder from [36] is used to reduce its complexity. The used code parameters are given in Table I.

TABLE I
PARAMETERS OF THE CONSTRUCTION .

	n	L	δ_M	δ_P	d	x	y	s_1	s_2
SC1A	960	150	4	3	20	9	3	$\frac{15n}{64}$	$\frac{9n}{64}$
SC1C	3840	150	4	3	20	9	3	$\frac{15n}{64}$	$\frac{9n}{64}$
SC2A	960	50	2	2	20	13	4	$\frac{23n}{96}$	$\frac{13n}{96}$

The x -axis and the y -axis of the following curves give respectively the depolarizing error probability and the probability of error after decoding. We have compared this code to codes of rate $\frac{1}{4}$, which is the design rate of our scheme when L grows. The other codes are taken from

- Garcia-Liu: [15]
- turbo codes: [27]
- MacKay: [13]
- Lou-Garcia: [35]
- Camara-Ollivier-Tillich: [14]

As shown in Fig. 4, the spatially coupled code clearly outperforms the previously known LDPC code constructions as well as the quantum turbo-code constructions.

Fig. 4. Comparison with other codes of rate $\frac{1}{4}$. The first dotted vertical line (B1) is the CSS lower bound (≈ 0.109), and the second (B2) is the hashing bound (≈ 0.127).

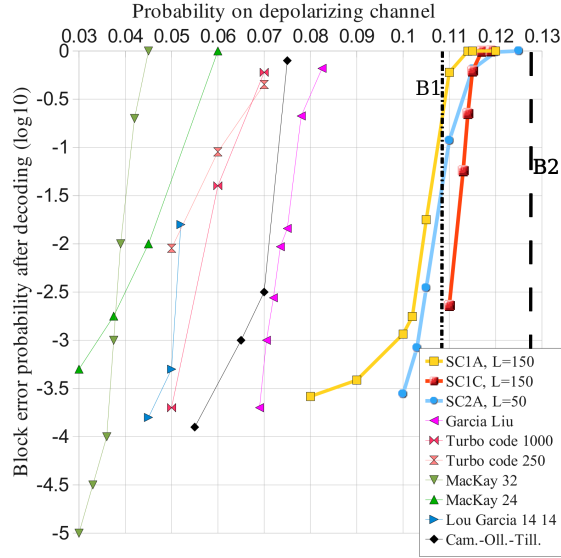

The performances are close to the hashing bound, formerly introduced, that gives $R = 1 - (\ln(p) + p \log_2(3))$.

We can even go beyond the CSS lower bound. This bound corresponds to the case when the X -part and the Z -part are decoded separately, therefore it corresponds to the lower bound of the decoding of the classical code given by the X -part, on a binary symmetric channel of error probability $2p/3$. This bound gives $R = 1 - 2h\left(\frac{2p}{3}\right)$, where R is the rate of the quantum code. Clearly, this shows that decoding the X and Z -parts together gives a quite good advantage.

REFERENCES

- [1] I. Andriyanova, D. Maurice, and J. P. Tillich, "Spatially coupled quantum LDPC codes," in *Proc. of Inf. Theor. Workshop ITW2012*, Lausanne, Switzerland, 2012, pp. 327–331.
- [2] M. Abbara and J. Tillich, "Quantum turbo codes with unbounded minimum distance and excellent error-reducing performance," in *Information Theory Workshop (ITW), 2011 IEEE*. IEEE, 2011, pp. 252–256.
- [3] G. Smith and J. Smolin, "Additive extensions of a quantum channel," in *Information Theory Workshop, 2008. ITW'08. IEEE*. IEEE, 2008, pp. 368–372.
- [4] S. Lloyd, "Capacity of the noisy quantum channel," *Phys. Rev. A*, vol. 55, p. 1613, 1997.
- [5] P. Shor, "The quantum channel capacity and coherent information," in *Lecture Notes, MSRI Workshop on Quantum Computation*, 2002.
- [6] I. Devetak, "The private classical capacity and quantum capacity of a quantum channel," *IEEE Trans. Info. Theor.*, vol. 51, p. 44, 2005.
- [7] D. P. DiVincenzo, P. W. Shor, and J. A. Smolin, "Quantum-channel capacity of very noisy channels," *Phys. Rev. A*, vol. 57, pp. 830–839, 1998.
- [8] G. Smith and J. A. Smolin, "Degenerate coding for Pauli channels," *Phys. Rev. Lett.*, vol. 98, 2007.
- [9] J. Fern and K. B. Whaley, "Lower bounds on the nonzero capacity of Pauli channels," *Phys. Rev. A*, vol. 78, p. 062335, Dec. 2008. [Online]. Available: <http://link.aps.org/doi/10.1103/PhysRevA.78.062335>
- [10] J. Renes, F. Dupuis, and R. Renner, "Efficient polar coding of quantum information," *Physical Review Letters*, vol. 109, no. 5, p. 50504, 2012.
- [11] E. Arıkan, "Channel polarization: a method for constructing capacity-achieving codes for symmetric binary-input memoryless channels," *IEEE Trans. on Information Theory*, vol. 55, no. 7, pp. 3051–3073, 2009.

- [12] M. H. Freedman, D. A. Meyer, and F. Luo, " \mathbb{Z}_2 -systolic freedom and quantum codes," in *Mathematics of quantum computation*, ser. Chapman & Hall/CRC, Boca Raton, FL, 2002, pp. 287–320.
- [13] D. J. C. MacKay, G. Mitchison, and P. L. MacFadden, "Sparse graph codes for quantum error-correction," *IEEE Trans. Info. Theor.*, vol. 50, no. 10, pp. 2315–2330, 2004.
- [14] T. Camara, H. Ollivier, and J.-P. Tillich, "A class of quantum LDPC codes: construction and performances under iterative decoding," in *Proceedings of ISIT 2007*. Nice: IEEE, June 2007, pp. 811–815.
- [15] J. Garcia-Frias and K. Liu, "Design of near-optimum quantum error-correcting codes based on generator and parity-check matrices of LDGM codes," in *Proceedings of CISS*, Princeton, Mar. 2008, pp. 562–567.
- [16] M. Hagiwara and H. Imai, "Quantum quasi-cyclic LDPC codes," in *Proc. IEEE Int. Symp. Info. Theo. (ISIT'07)*. Nice: IEEE, June 2007, pp. 806–811.
- [17] I. B. Djordjevic, "Quantum LDPC codes from incomplete block designs," *IEEE Communication Letters*, vol. 12, no. 5, pp. 389–391, May 2008.
- [18] S. A. Aly, "A class of quantum LDPC codes constructed from finite geometries," in *Proceedings of IEEE GLOBECOM 2008*, Dec. 2008, pp. 1–5.
- [19] M.-H. Hsieh, T. A. Brun, and I. Devetak, "Quantum quasi-cyclic low-density parity check codes," Mar. 2008, arXiv:0803.0100v1 [quant-ph].
- [20] P. Tan and J. Li, "Efficient quantum stabilizer codes: LDPC and LDPC-convolutional constructions," *IEEE Trans. Info. Theor.*, vol. 56, no. 1, pp. 476–491, 2010.
- [21] I. H. Kim, "Quantum codes on Hurwitz surfaces," Master's thesis, MIT, 2007, available at <http://dspace.mit.edu/handle/1721.1/40917>.
- [22] K. P. Sarvepalli, M. Rötteler, and A. Klappenecker, "Asymmetric quantum LDPC codes," in *Proceedings of ISIT 2008*, IEEE, Ed., Toronto, Canada, July 2008, pp. 305–309.
- [23] G. Zémor, "On Cayley graphs, surface codes and the limits of homological coding for quantum error correction," in *Coding and Cryptology, 2nd international Workshop IWCC 2009*, ser. LNCS, vol. 5557, 2009, pp. 259–273.
- [24] J.-P. Tillich and G. Zémor, "Quantum LDPC codes with positive rate and minimum distance proportional to $n^{\frac{1}{2}}$," in *Proceedings of ISIT 2009*, July 2009, pp. 799–803.
- [25] D. Poulin and Y. Chung, "On the iterative decoding of sparse quantum codes," *Quantum Information and Computation*, vol. 8, p. 987, 2008. [Online]. Available: <http://www.citebase.org/abstract?id=doi:arXiv.org:0801.1241>
- [26] H. Ollivier and J.-P. Tillich, "Interleaved serial concatenation of quantum convolutional codes: gate implementation and iterative error estimation algorithm," in *Proceedings of the 26th Symposium on Information Theory in the Benelux*, Brussels, Belgium, 2005, p. 149.
- [27] D. Poulin, J.-P. Tillich, and H. Ollivier, "Quantum serial turbo-codes," *IEEE Trans. Info. Theor.*, vol. 55, no. 6, pp. 2776–2798, June 2009.
- [28] S. Kudekar, T. Richardson, and R. Urbanke, "Spatially coupled ensembles universally achieve capacity under belief propagation," arxiv:1201.2999v1 [cs.IT], Jan. 2012, arxiv:1201.2999v1 [cs.IT].
- [29] A. J. Felström and K. S. Zigangirov, "Time-varying periodic convolutional codes with low-density parity-check matrix," *IEEE Trans. on Information Theory*, vol. 45, no. 5, pp. 2181–2190, 1999.
- [30] M. Hagiwara, K. Kasai, H. Imai, and K. Sakaniwa, "Spatially coupled quasi-cyclic quantum LDPC codes," in *Proc. IEEE Int. Symp. Info. Theo.*, 2011, pp. 638–642.
- [31] A. R. Calderbank and P. W. Shor, "Good quantum error-correcting codes exist," *Phys. Rev. A*, vol. 54, pp. 1098–1105, 1996.
- [32] A. M. Steane, "Multiple particle interference and quantum error correction," *Proc. R. Soc. Lond. A*, vol. 452, pp. 2551–2577, 1996.
- [33] D. Gottesman, "Stabilizer codes and quantum error correction," Ph.D. dissertation, California Institute of Technology, Pasadena, CA, 1997.
- [34] A. R. Calderbank, E. M. Rains, P. W. Shor, and N. J. A. Sloane, "Quantum error correction via codes over $GF(4)$," *IEEE Trans. Info. Theor.*, vol. 44, p. 1369, 1998.
- [35] H. Lou and J. Garcia-Frias, "On the application of error-correcting codes with low-density generator matrix over different quantum channels," in *Proceedings of Turbo-coding 2006*, Munich, April 2006.
- [36] M. Lentmaier and G. Fettweis, "Coupled LDPC codes: Complexity aspects of threshold saturation," in *Proc. of the IEEE Inform. Theory Workshop*, Paraty, Brasil 2011, pp. 668–672.